

# eCANTER 4S15e

## LEFT-HAND DRIVE

### MODEL / VEHICLE TYPE 4S15e

Cab type / crew	Standard, single cab / 3			
Battery variant	S			M
Model variant	84000211	84000311	84000511	84001511
FUSO model code	FEAVKBLCSEU3	FEAVKCLCSEU3	FEAVKELCSEU3	FEAVKELDSEU3

### DIMENSIONS [MM]

Wheelbase	2500	2800	3400	
Overall length	4766	5044	5788	
Cab length	1510			
Width overall	1798			
Cab width	1695			
Height overall	2120 – 2238	2150 – 2238	2148 – 2238	2141 – 2229
Track width	Front / rear		1390 / 1435	
Frame height (at end of frame)	150			
Ground clearance	260			250
Cab to rear axle	1975	2278	2781	
Cab to end of frame	3128	3478	4278	
Maximum body length <sup>3)</sup>	3500	3995	4985	
Frame width	701			
Front overhang	993			
Rear overhang	1145	1195	1395	
Front axle to front of body	625			
Recommended distance cab to body	100			

### WEIGHTS [KG]

Empty weight <sup>1)</sup>		2595	2605	2630	3105
	Front / rear	1510 / 1085	1535 / 1070	1555 / 1075	1735 / 1370
Gross vehicle weight	4150 (4000 <sup>2)</sup> )				
Technical axle loads <sup>1)</sup>	Front / rear	2600 / 3200			
Chassis load bearing capacity <sup>3)</sup>		1555 (1405 <sup>2)</sup> )	1545 (1395 <sup>2)</sup> )	1520 (1370 <sup>2)</sup> )	1145

### DRIVING PERFORMANCE AND AGILITY

Maximum speed	km/h	89			
Minimum turning circle [m]	Kerb to kerb	9.8	10.8	12.8	
	Wall to wall	10.8	12.0	14.0	

1) The weight refers to the base vehicle (European series, including high voltage battery, tyre sealant, tools and driver with 75 kg) without optional equipment. If any optional equipment is added, the weight changes accordingly.  
 2) Optional GVW variant (e.g. for vehicles registered in France) with associated maximum values for the calculated chassis load bearing capacity.  
 3) Calculated maximum value which should be checked depending on the body and application.  
 Subject to change without notice. All data is approximate.

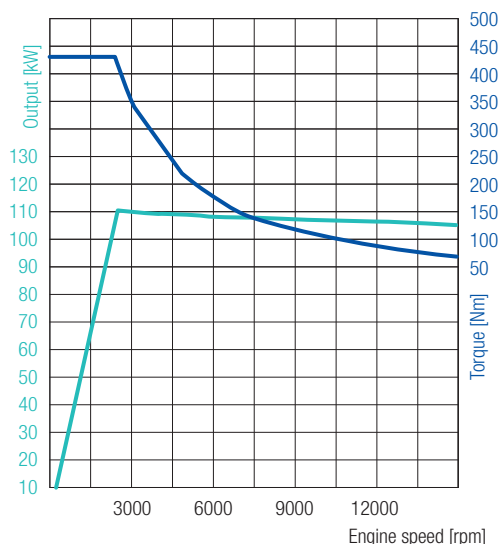
**110 kW (150 hp)**  
430 Nm

## eCANTER 4S15e

### LEFT-HAND DRIVE

#### ELECTRIC DRIVE

Type	S40		
Peak output / continuous output	110 kW (150 hp) / 85 kW (116 hp)		
Maximum torque / continuous torque	430 Nm / 250 Nm		
PTO (optional)	Type	mPTO for pump connection	mPTO for pulley
	Maximum torque	222 Nm at 2000 rpm	64 Nm at 7000 rpm
	Continuous power / torque	17 kW / 166 Nm, maximum 2000 rpm	17 kW / 46 Nm, maximum 7000 rpm
	Gear ratio	0.286	–

#### HIGH VOLTAGE BATTERY

Battery variant	S		M
Capacity usable / installed	kWh	39 / 41	78 / 82
Weight <sup>4)</sup>	kg	475	950
Range <sup>5)</sup>	km	70	140

#### CHARGING

Connection type / variants	CCS TYP 2 (AC / DC)		
Maximum charging capacity AC / DC	kW	11 / 70	22 / 104
Maximum charging time AC <sup>6)</sup>	0–100 % h:min	4:12	4:54
Maximum charging time DC <sup>6)</sup>	20–80 % h:min	0:24	0:26
	5–90 % h:min	0:36	0:44

#### POWERTRAIN

Climbing ability	20 %
------------------	------

#### CHASSIS

Front axle / rear axle	Independent suspension / E-axle		
Tyres	205/75 R 17.5		
Wheel	17.5 x 6.00 - 115		
Steering	Left-hand drive	Recirculating ball steering with power assist, tilting telescopic steering column with steering-wheel lock	
Brake	Service brake	Hydraulic with vacuum power assist, dual-circuit with load-dependent brake proportioning valve at rear wheels	
	Front / rear	Disc brake (293 x 40 mm / 314 x 35 mm)	
	Parking brake	Electromechanical brake caliper on rear disc brake	
Suspension	Front / rear	Coil springs with shock absorber / Semi-elliptic leaf springs with shock absorber and stabilizer	
Frame	Type	Ladder-type frame with reinforcements and crossmembers	
Electrical system	Low voltage batteries	Series 12 V (80 Ah), optional 24 V (80 + 60 Ah)	

4) The specified weight includes both the battery(ies) with 325 kg each and the peripheral installations (cabling, temperature control, protection, etc.).

5) The range depends on various factors such as load, driving style, topography, ambient temperature or weather, battery age, vehicle equipment. The actual range may vary.

The given values for the range were tested with a box body, a load of 50 % of the payload, an ambient temperature of 20 °C and an average battery age.

6) The charging time depends on various factors such as the charging capacity of the vehicle and charging station, the battery's state of charge, ambient and battery temperature.

The given values for the charging time were tested under optimum ambient temperature of 20 °C.

The illustrations may contain accessories and items of optional equipment which are not part of the standard specification. The data sheet may contain product types and support services not available in certain countries.

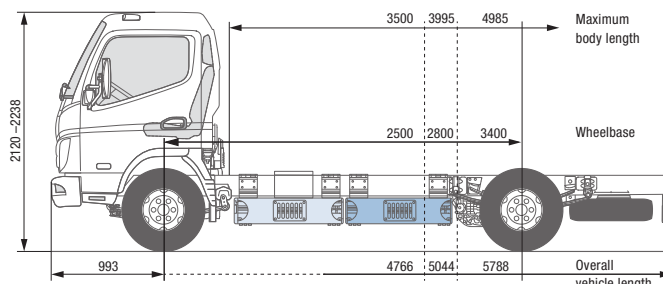
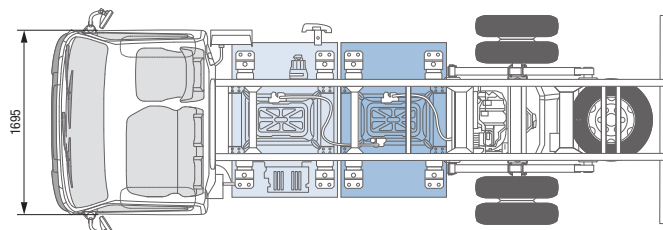

# eCANTER 4S15e

## RIGHT-HAND DRIVE

### MODEL / VEHICLE TYPE 4S15e

Cab type / crew	Standard, single cab / 3			
Battery variant	S			M
Model variant	84000221	84000321	84000521	84001521
FUSO model code	FEAVKBRCEU3	FEAVKRCSEU3	FEAVKRCSEU3	FEAVKERDSEU3

### DIMENSIONS [MM]

Wheelbase	2500	2800	3400	
Overall length	4766	5044	5788	
Cab length	1510			
Width overall	1798			
Cab width	1695			
Height overall	2120 – 2238	2150 – 2238	2148 – 2238	2141 – 2229
Track width	Front / rear		1390 / 1435	
Frame height (at end of frame)	150			
Ground clearance	260			250
Cab to rear axle	1975	2278	2781	
Cab to end of frame	3128	3478	4278	
Maximum body length <sup>3)</sup>	3500	3995	4985	
Frame width	701			
Front overhang	993			
Rear overhang	1145	1195	1395	
Front axle to front of body	625			
Recommended distance cab to body	100			

### WEIGHTS [KG]

Empty weight <sup>1)</sup>		2595	2605	2630	3105
	Front / rear	1510 / 1085	1535 / 1070	1555 / 1075	1735 / 1370
Gross vehicle weight		4150 (4000 <sup>2)</sup> )			4250
Technical axle loads <sup>1)</sup>	Front / rear	2600 / 3200			
Chassis load bearing capacity <sup>3)</sup>		1555 (1405 <sup>2)</sup> )	1545 (1395 <sup>2)</sup> )	1520 (1370 <sup>2)</sup> )	1145

### DRIVING PERFORMANCE AND AGILITY

Maximum speed	km/h	89			
Minimum turning circle [m]	Kerb to kerb	9.8	10.8	12.8	
	Wall to wall	10.8	12.0	14.0	

1) The weight refers to the base vehicle (European series, including high voltage battery, tyre sealant, tools and driver with 75 kg) without optional equipment. If any optional equipment is added, the weight changes accordingly.  
 2) Optional GVW variant (e.g. for vehicles registered in France) with associated maximum values for the calculated chassis load bearing capacity.  
 3) Calculated maximum value which should be checked depending on the body and application.  
 Subject to change without notice. All data is approximate.

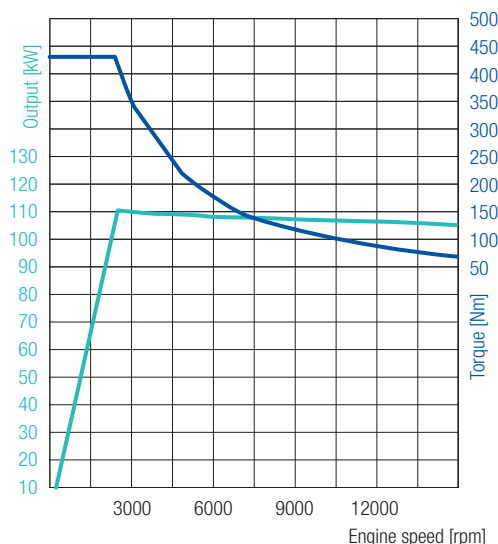

## eCANTER 4S15e RIGHT-HAND DRIVE

**110 kW (150 hp)**  
430 Nm

### ELECTRIC DRIVE

Type	S40		
Peak output / continuous output	110 kW (150 hp) / 85 kW (116 hp)		
Maximum torque / continuous torque	430 Nm / 250 Nm		
PTO (optional)	Type	mPTO for pump connection	mPTO for pulley
	Maximum torque	222 Nm at 2000 rpm	64 Nm at 7000 rpm
	Continuous power / torque	17 kW / 166 Nm, maximum 2000 rpm	17 kW / 46 Nm, maximum 7000 rpm
	Gear ratio	0.286	–

### HIGH VOLTAGE BATTERY

Battery variant	S		M
Capacity usable / installed	kWh	39 / 41	78 / 82
Weight <sup>4)</sup>	kg	475	950
Range <sup>5)</sup>	km	70	140

### CHARGING

Connection type / variants	CCS TYP 2 (AC / DC)		
Maximum charging capacity AC / DC	kW	11 / 70	22 / 104
Maximum charging time AC <sup>6)</sup>	0–100 % h:min	4:12	4:54
Maximum charging time DC <sup>6)</sup>	20–80 % h:min	0:24	0:26
	5–90 % h:min	0:36	0:44

### POWERTRAIN

Climbing ability	20 %
------------------	------

### CHASSIS

Front axle / rear axle	Independent suspension / E-axle		
Tyres	205/75 R 17.5		
Wheel	17.5 x 6.00 - 115		
Steering	Right-hand drive	Recirculating ball steering with power assist, tilting telescopic steering column with steering-wheel lock	
Brake	Service brake	Hydraulic with vacuum power assist, dual-circuit with load-dependent brake proportioning valve at rear wheels	
	Front / rear	Disc brake (293 x 40 mm / 314 x 35 mm)	
	Parking brake	Electromechanical brake caliper on rear disc brake	
Suspension	Front / rear	Coil springs with shock absorber / Semi-elliptic leaf springs with shock absorber and stabilizer	
Frame	Type	Ladder-type frame with reinforcements and crossmembers	
Electrical system	Low voltage batteries	Series 12 V (80 Ah), optional 24 V (80 + 60 Ah)	

4) The specified weight includes both the battery(ies) with 325 kg each and the peripheral installations (cabling, temperature control, protection, etc.).

5) The range depends on various factors such as load, driving style, topography, ambient temperature or weather, battery age, vehicle equipment. The actual range may vary.

The given values for the range were tested with a box body, a load of 50 % of the payload, an ambient temperature of 20 °C and an average battery age.

6) The charging time depends on various factors such as the charging capacity of the vehicle and charging station, the battery's state of charge, ambient and battery temperature.

The given values for the charging time were tested under optimum ambient temperature of 20 °C.

The illustrations may contain accessories and items of optional equipment which are not part of the standard specification. The data sheet may contain product types and support services not available in certain countries.

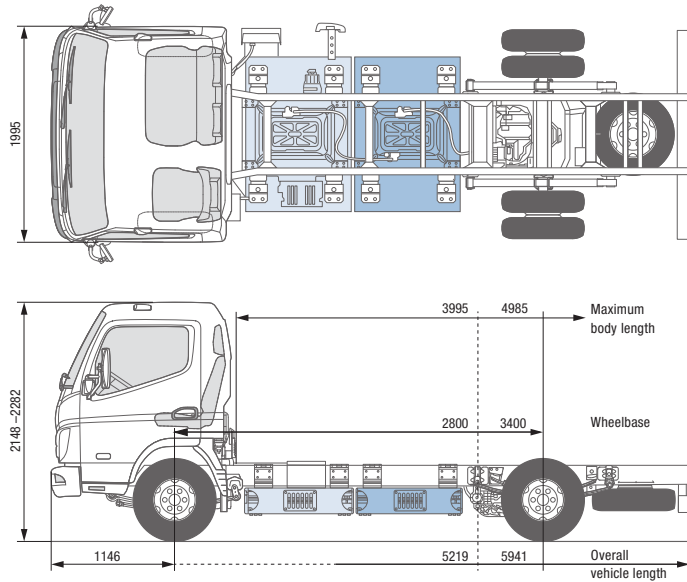

## eCANTER 4C15e LEFT-HAND DRIVE

MODEL / VEHICLE TYPE		4C15e		
Cab type / crew		Comfort, single cab / 3		
Battery variant		S		M
Model variant		84002311	84002511	84003511
FUSO model code		FEBVKLCLSEU3	FEBVKELCSEU3	FEBVKELDSEU3
DIMENSIONS [MM]				
Wheelbase		2800	3400	
Overall length		5219	5941	
Cab length		1631		
Width overall		2098		
Cab width		1995		
Height overall		2186–2282	2148–2282	2177–2273
Track width		Front / rear		1655 / 1490
Frame height (at end of frame)		152		
Ground clearance		260	265	
Cab to rear axle		2275	2875	
Cab to end of frame		3510	4310	
Maximum body length <sup>3)</sup>		3995	4985	
Frame width		752		
Front overhang		1146		
Rear overhang		1195	1395	
Front axle to front of body		625		
Recommended distance cab to body		100		
WEIGHTS [KG]				
Empty weight <sup>1)</sup>		2735	2755	3220
		Front / rear		1660 / 1075
Gross vehicle weight		4180 (4000 <sup>2)</sup> )		4250
Technical axle loads <sup>1)</sup>		Front / rear		2600 / 3200
Chassis load bearing capacity <sup>3)</sup>		1445 (1265 <sup>2)</sup> )	1425 (1245 <sup>2)</sup> )	1030
DRIVING PERFORMANCE AND AGILITY				
Maximum speed		km/h		89
Minimum turning circle [m]		Kerb to kerb		10.2
		Wall to wall		11.6
				13.4

1) The weight refers to the base vehicle (European series, including high voltage battery, tyre sealant, tools and driver with 75 kg) without optional equipment. If any optional equipment is added, the weight changes accordingly.

2) Optional GVW variant (e.g. for vehicles registered in France) with associated maximum values for the calculated chassis load bearing capacity.

3) Calculated maximum value which should be checked depending on the body and application.

Subject to change without notice. All data is approximate.



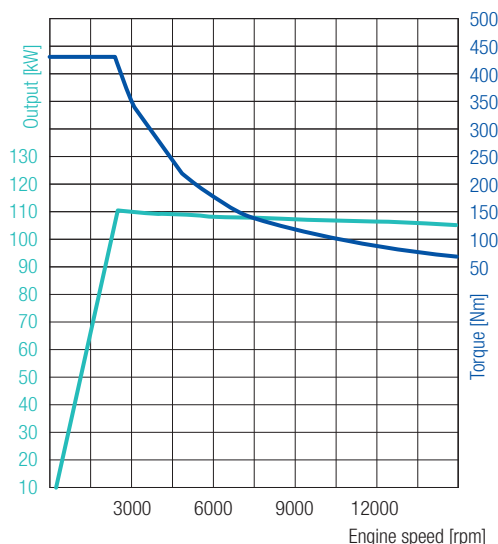

## eCANTER 4C15e

### LEFT-HAND DRIVE

**110 kW (150 hp)**  
430 Nm

#### ELECTRIC DRIVE

Type	S40		
Peak output / continuous output	110 kW (150 hp) / 85 kW (116 hp)		
Maximum torque / continuous torque	430 Nm / 250 Nm		
PTO (optional)	Type	mPTO for pump connection	mPTO for pulley
	Maximum torque	222 Nm at 2000 rpm	64 Nm at 7000 rpm
	Continuous power / torque	17 kW / 166 Nm, maximum 2000 rpm	17 kW / 46 Nm, maximum 7000 rpm
	Gear ratio	0.286	–

#### HIGH VOLTAGE BATTERY

Battery variant	S		M
Capacity usable / installed	kWh	39 / 41	78 / 82
Weight <sup>4)</sup>	kg	470	940
Range <sup>5)</sup>	km	70	140

#### CHARGING

Connection type / variants	CCS TYP 2 (AC / DC)		
Maximum charging capacity AC / DC	kW	11 / 70	22 / 104
Maximum charging time AC <sup>6)</sup>	0–100 % h:min	4:12	4:54
Maximum charging time DC <sup>6)</sup>	20–80 % h:min	0:24	0:26
	5–90 % h:min	0:36	0:44

#### POWERTRAIN

Climbing ability	20 %
------------------	------

#### CHASSIS

Front axle / rear axle	Independent suspension / E-axle	
Tyres	205/75 R 17.5	
Wheel	17.5 x 6.00 - 115	
Steering	Left-hand drive	Recirculating ball steering with power assist, tilting telescopic steering column with steering-wheel lock
Brake	Service brake	Hydraulic with vacuum power assist, dual-circuit with load-dependent brake proportioning valve at rear wheels
	Front / rear	Disc brake (293 x 40 mm / 314 x 35 mm)
	Parking brake	Electromechanical brake caliper on rear disc brake
Suspension	Front / rear	Coil springs with shock absorber / Semi-elliptic leaf springs with shock absorber and stabilizer
Frame	Type	Ladder-type frame with reinforcements and crossmembers
Electrical system	Low voltage batteries	Series 12 V (80 Ah), optional 24 V (80 + 60 Ah)

4) The specified weight includes both the battery(ies) with 325 kg each and the peripheral installations (cabling, temperature control, protection, etc.).

5) The range depends on various factors such as load, driving style, topography, ambient temperature or weather, battery age, vehicle equipment. The actual range may vary.

The given values for the range were tested with a box body, a load of 50 % of the payload, an ambient temperature of 20 °C and an average battery age.

6) The charging time depends on various factors such as the charging capacity of the vehicle and charging station, the battery's state of charge, ambient and battery temperature.

The given values for the charging time were tested under optimum ambient temperature of 20 °C.

The illustrations may contain accessories and items of optional equipment which are not part of the standard specification. The data sheet may contain product types and support services not available in certain countries.

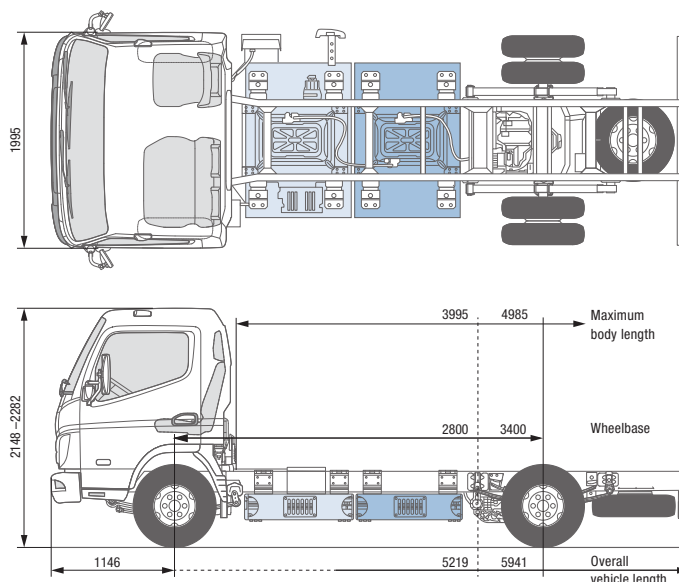

## eCANTER 4C15e RIGHT-HAND DRIVE

### MODEL / VEHICLE TYPE

	4C15e		
Cab type / crew	Comfort, single cab / 3		
Battery variant	S		M
Model variant	84002321	84002521	84003521
FUSO model code	FEBVKCRCSEU3	FEBVKERCSEU3	FEBVKERDSEU3

### DIMENSIONS [MM]

Wheelbase		2800	3400
Overall length		5219	5941
Cab length			1631
Width overall			2098
Cab width			1995
Height overall		2186–2282	2148–2282
Track width	Front / rear		1655 / 1490
Frame height (at end of frame)			152
Ground clearance		260	265
Cab to rear axle		2275	2875
Cab to end of frame		3510	4310
Maximum body length <sup>3)</sup>		3995	4985
Frame width			752
Front overhang			1146
Rear overhang		1195	1395
Front axle to front of body			625
Recommended distance cab to body			100

### WEIGHTS [KG]

Empty weight <sup>1)</sup>		2735	2755	3220
	Front / rear	1660 / 1075	1685 / 1070	1860 / 1360
Gross vehicle weight		4180 (4000 <sup>2)</sup> )		4250
Technical axle loads <sup>1)</sup>	Front / rear		2600 / 3200	
Chassis load bearing capacity <sup>3)</sup>		1445 (1265 <sup>2)</sup> )	1425 (1245 <sup>2)</sup> )	1030

### DRIVING PERFORMANCE AND AGILITY

Maximum speed	km/h	89	
Minimum turning circle [m]	Kerb to kerb	10.2	12.0
	Wall to wall	11.6	13.4

1) The weight refers to the base vehicle (European series, including high voltage battery, tyre sealant, tools and driver with 75 kg) without optional equipment. If any optional equipment is added, the weight changes accordingly.

2) Optional GVW variant (e.g. for vehicles registered in France) with associated maximum values for the calculated chassis load bearing capacity.

3) Calculated maximum value which should be checked depending on the body and application.

Subject to change without notice. All data is approximate.

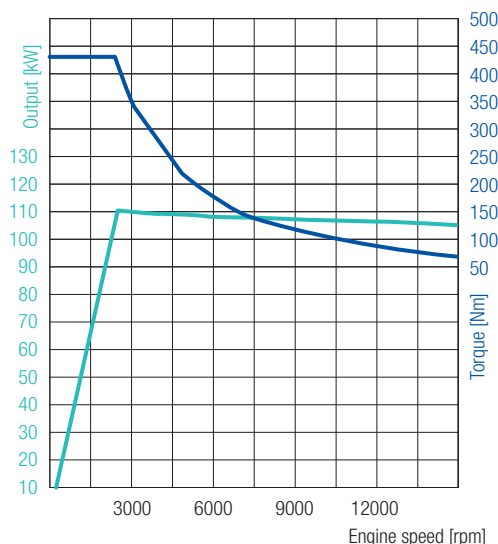

**110 kW (150 hp)**  
430 Nm

## eCANTER 4C15e RIGHT-HAND DRIVE

### ELECTRIC DRIVE

Type	S40		
Peak output / continuous output	110 kW (150 hp) / 85 kW (116 hp)		
Maximum torque / continuous torque	430 Nm / 250 Nm		
PTO (optional)	Type	mPTO for pump connection	mPTO for pulley
	Maximum torque	222 Nm at 2000 rpm	64 Nm at 7000 rpm
	Continuous power / torque	17 kW / 166 Nm, maximum 2000 rpm	17 kW / 46 Nm, maximum 7000 rpm
	Gear ratio	0.286	–

### HIGH VOLTAGE BATTERY

Battery variant	S		M
Capacity usable / installed	kWh	39 / 41	78 / 82
Weight <sup>4)</sup>	kg	470	940
Range <sup>5)</sup>	km	70	140

### CHARGING

Connection type / variants	CCS TYP 2 (AC / DC)		
Maximum charging capacity AC / DC	kW	11 / 70	22 / 104
Maximum charging time AC <sup>6)</sup>	0–100 % h:min	4:12	4:54
Maximum charging time DC <sup>6)</sup>	20–80 % h:min	0:24	0:26
	5–90 % h:min	0:36	0:44

### POWERTRAIN

Climbing ability	20 %
------------------	------

### CHASSIS

Front axle / rear axle	Independent suspension / E-axle	
Tyres	205/75 R 17.5	
Wheel	17.5 x 6.00 - 115	
Steering	Right-hand drive	Recirculating ball steering with power assist, tilting telescopic steering column with steering-wheel lock
Brake	Service brake	Hydraulic with vacuum power assist, dual-circuit with load-dependent brake proportioning valve at rear wheels
	Front / rear	Disc brake (293 x 40 mm / 314 x 35 mm)
	Parking brake	Electromechanical brake caliper on rear disc brake
Suspension	Front / rear	Coil springs with shock absorber / Semi-elliptic leaf springs with shock absorber and stabilizer
Frame	Type	Ladder-type frame with reinforcements and crossmembers
Electrical system	Low voltage batteries	Series 12 V (80 Ah), optional 24 V (80 + 60 Ah)

4) The specified weight includes both the battery(ies) with 325 kg each and the peripheral installations (cabling, temperature control, protection, etc.).

5) The range depends on various factors such as load, driving style, topography, ambient temperature or weather, battery age, vehicle equipment. The actual range may vary.

The given values for the range were tested with a box body, a load of 50 % of the payload, an ambient temperature of 20 °C and an average battery age.

6) The charging time depends on various factors such as the charging capacity of the vehicle and charging station, the battery's state of charge, ambient and battery temperature.

The given values for the charging time were tested under optimum ambient temperature of 20 °C.

The illustrations may contain accessories and items of optional equipment which are not part of the standard specification. The data sheet may contain product types and support services not available in certain countries.